

D

C

B

A

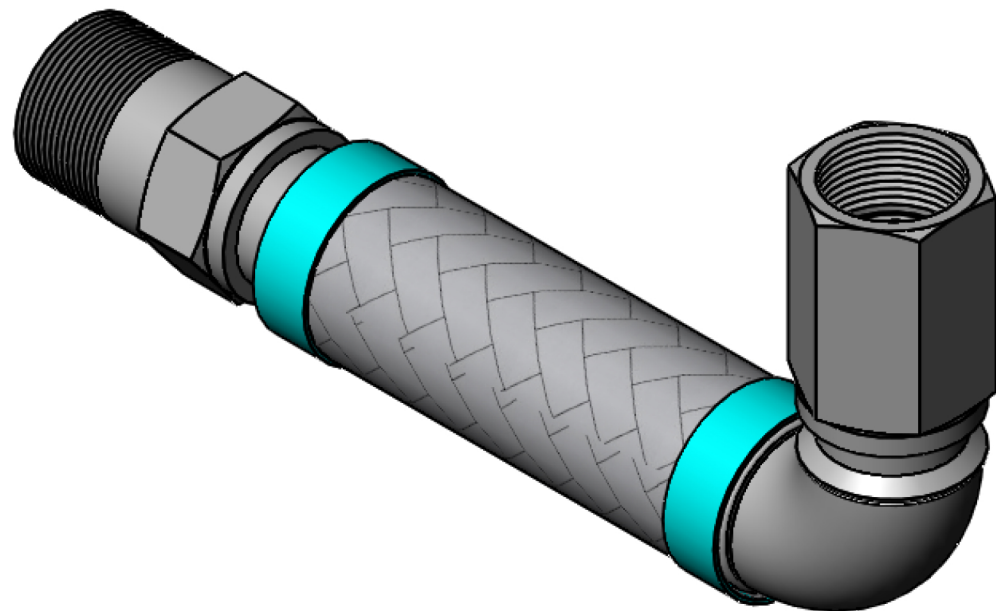
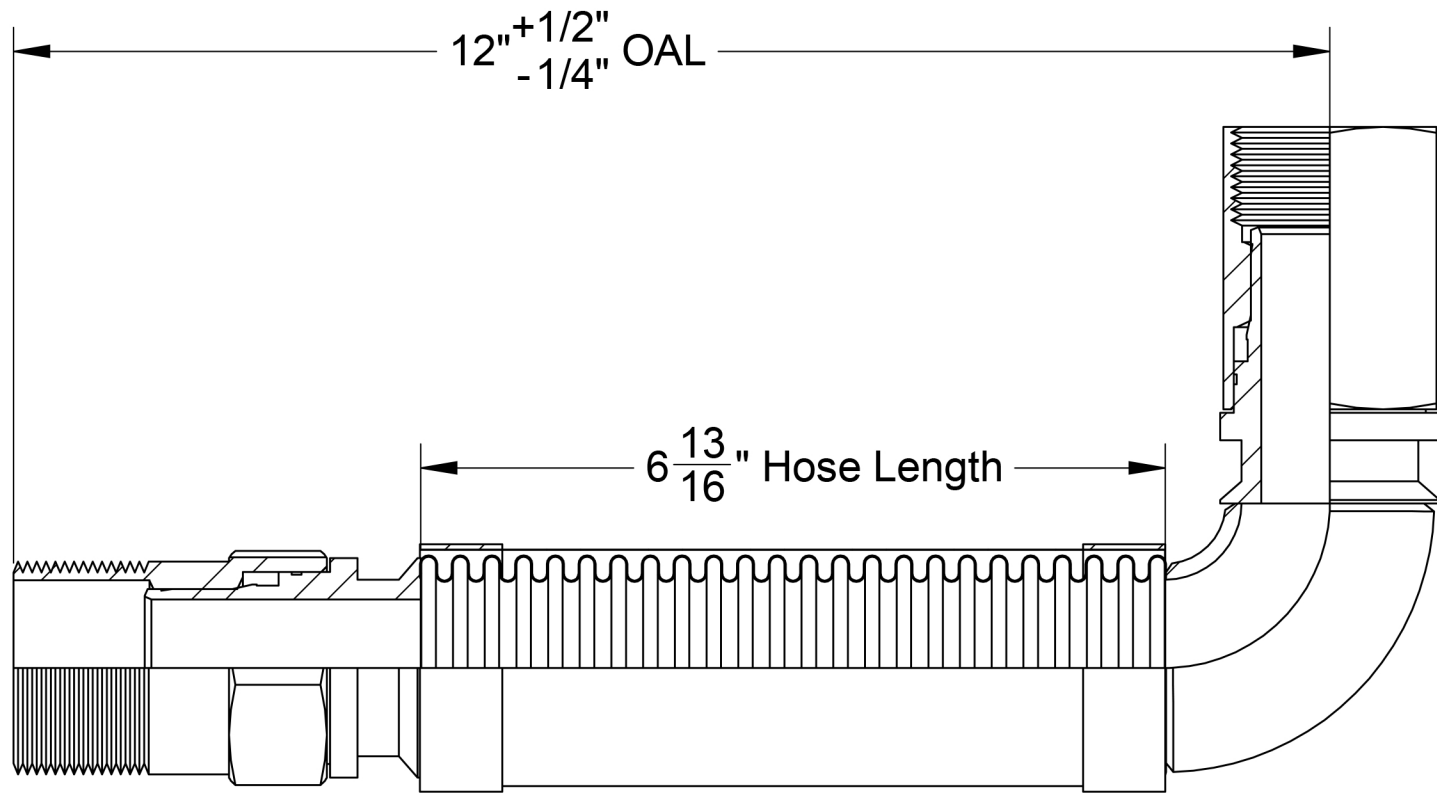

ITEM #	QTY.	PART NUMBER	DESCRIPTION	MATERIAL	WEIGHT
1	1	HOSE	300 Series Stainless HYDROFORMED Corrugated Hose	Stainless Steel	0.29
2	1	BRAID	300 Series Stainless Steel	Stainless Steel	0.03
3	2	BRAID COLLAR	0.05" Thick	Stainless Steel	0.07
4	1	1.5" MALE SWIVEL	1.5" Male Swivel, 1-1/2"x11-1/2" Thread, 1.94" Hex	Carbon Steel	1.40
5	1	1.5" ELBOW	1.5" Short Radius Elbow, Sch. 40	Carbon Steel	0.52
6	1	1.5 in Female Swivel Assem	1.5" Female Swivel, 1-1/2"x11-1/2" Thread, 1.94" Hex	Carbon Steel	1.44



**HOSE MASTER Inc.**

1233 East 222nd Street • Cleveland, Ohio 44117  
 (800) 221-2319 • Fax: (216) 481-7557 • www.hosemaster.com  
 Locations: **Cleveland • Houston**

Registered to:  
ISO 9001 : 2000



Projection:	Customer: Hose Master Inc.	Prepared By: <b>kannk</b>
	Reference: Fire-Shield - 1.5" Male Swivel x 1.5" 90 Degree Female Swivel x 12 " OAL	CALC. WEIGHT: <b>4 lbs.</b> Date: <b>9/24/2009</b>
	Description: <b>1.5" ID x 12" OAL 300 Series Stainless HYDROFORMED Corrugated Hose covered by 300 Series Stainless Braid. UL Approved 1.5" Male Swivel Connector x 1.5" ID 90 Degree Female Swivel Connector</b>	
	Drawing #: <b>FSSWE0150x12</b>	Rev.: - SHEET 1 OF 1

REVISIONS			
REV.	DESCRIPTION	DATE	APPROVED
8		7	6